

INSTALLATION INFORMATION

WEIGHT: 90 LBS / 41 KG

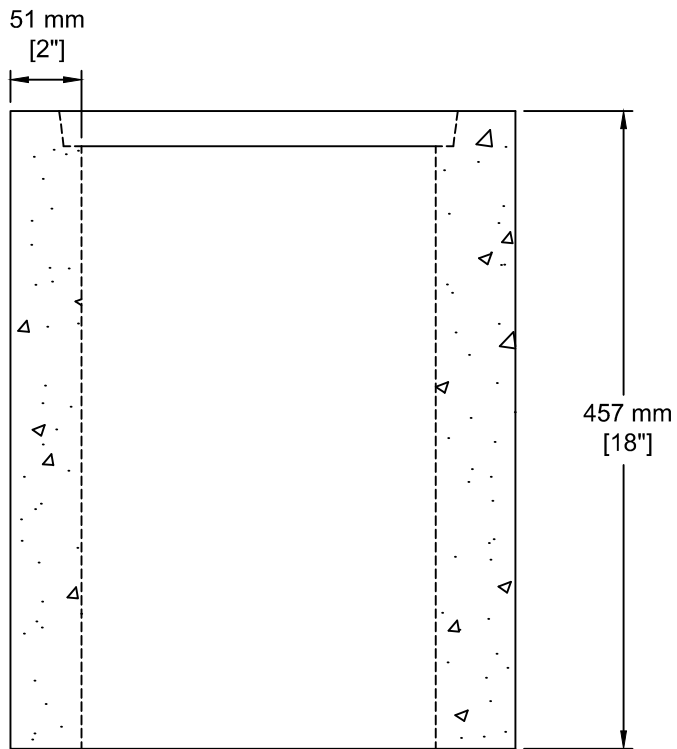

254 mm ID (10") x 0.46vm
Clean-out Ring

Product #

1865



TEL: 250-495-7556
socp@socp.ca
www.socp.ca