

**INSTALLATION INFORMATION**

**WEIGHT: 80 LBS / 36 KG**

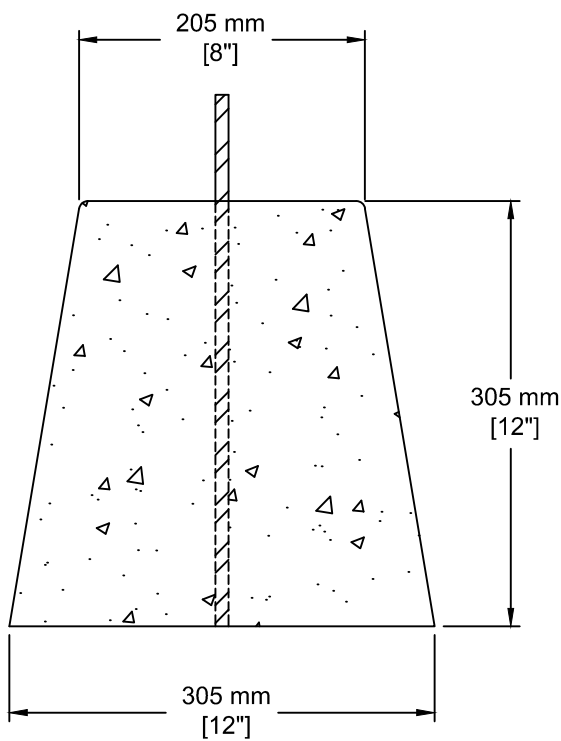

TEL: 250-495-7556  
 socp@socp.ca  
 www.socp.ca

**Pyramid Block  
 /c 10mm [3/8"] pin**

**Product #**

**1861**