

**INSTALLATION INFORMATION**

2 - 2.5T DOGBONE STYLE LIFTING ANCHORS

WEIGHT: 1598 LBS / 725 KG

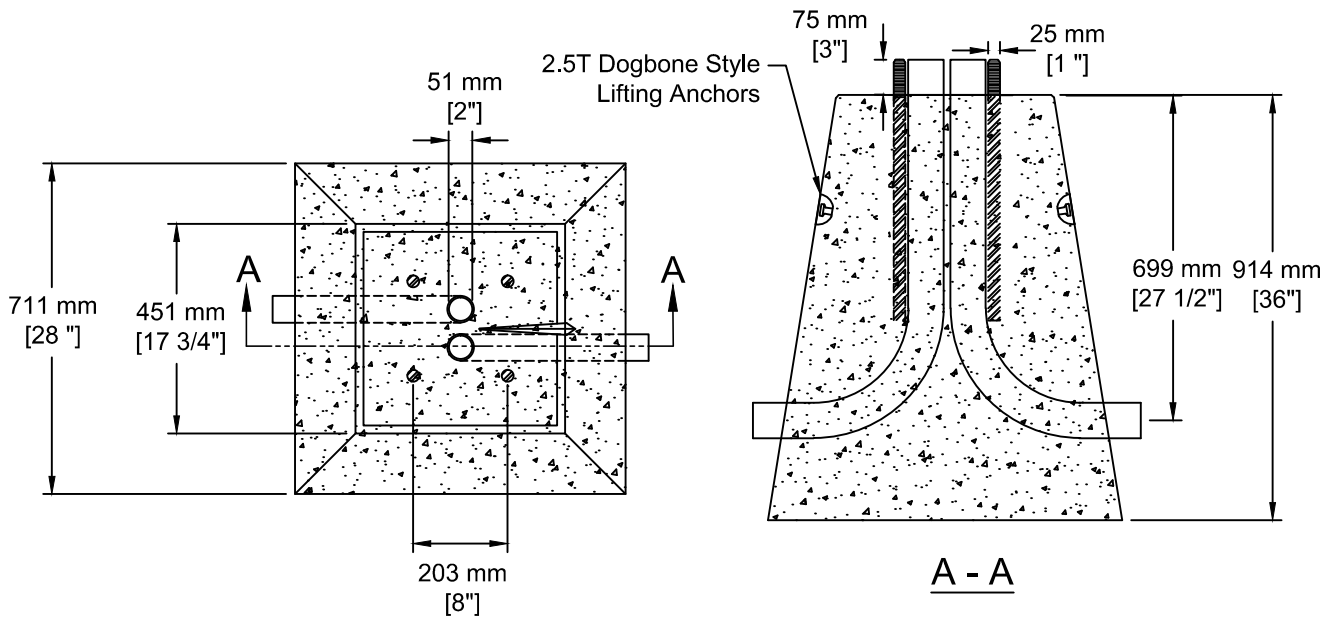

TEL: 250-495-7556  
 socp@socp.ca  
 www.socp.ca

**SL-5 Osoyoos Walkway  
 Concrete Street Light Base**

Product #  
**1250**