

**INSTALLATION INFORMATION**

MANUFACTURED IN ACCORDANCE WITH CSA A23.4

2 - 2.5T DOGBONE STYLE LIFTING ANCHORS

WEIGHT: 1598 LBS / 725 KG

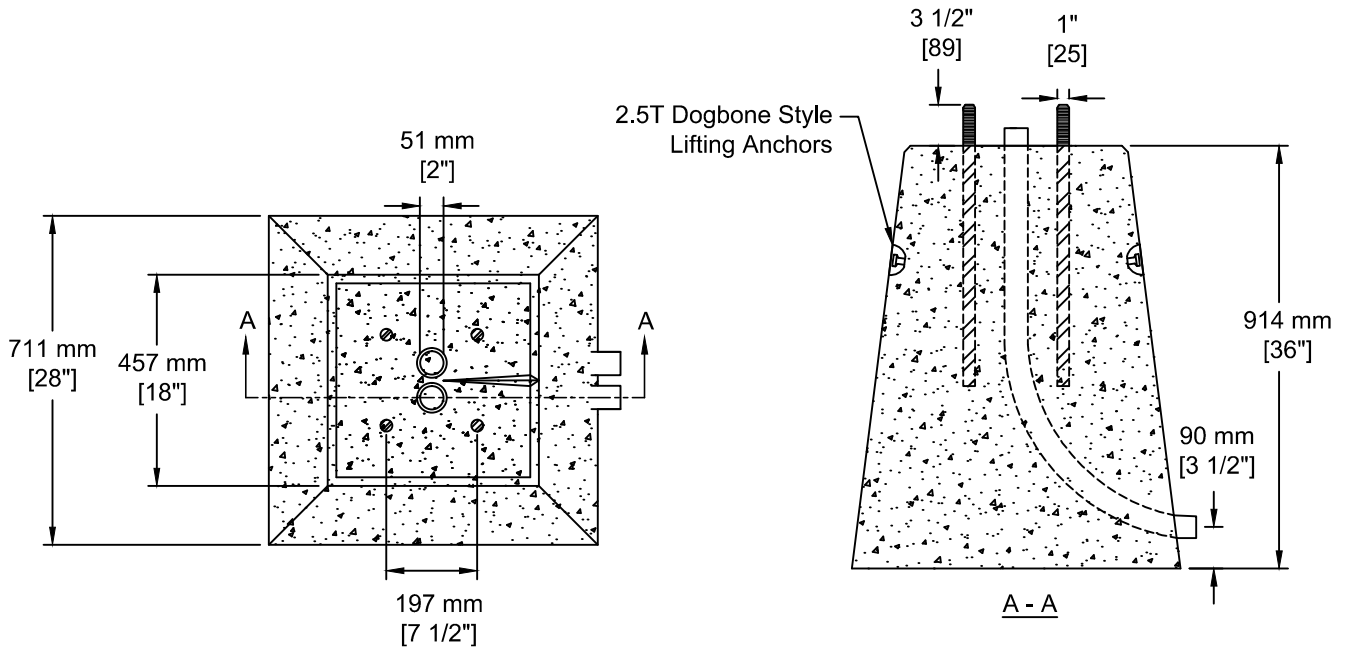

Fortis # 755-0206



TEL: 250-495-7556  
 socp@socp.ca  
 www.socp.ca

1416 Fortis 0.9M (3')  
 Street Light Base - Residential

Product #

**1132**