

**INSTALLATION INFORMATION**  
 DESIGNED FOR H-20 DYNAMIC LOADING  
 4 - 2.5T DOGBONE STYLE LIFTING ANCHORS  
 WEIGHT: LBS / KG

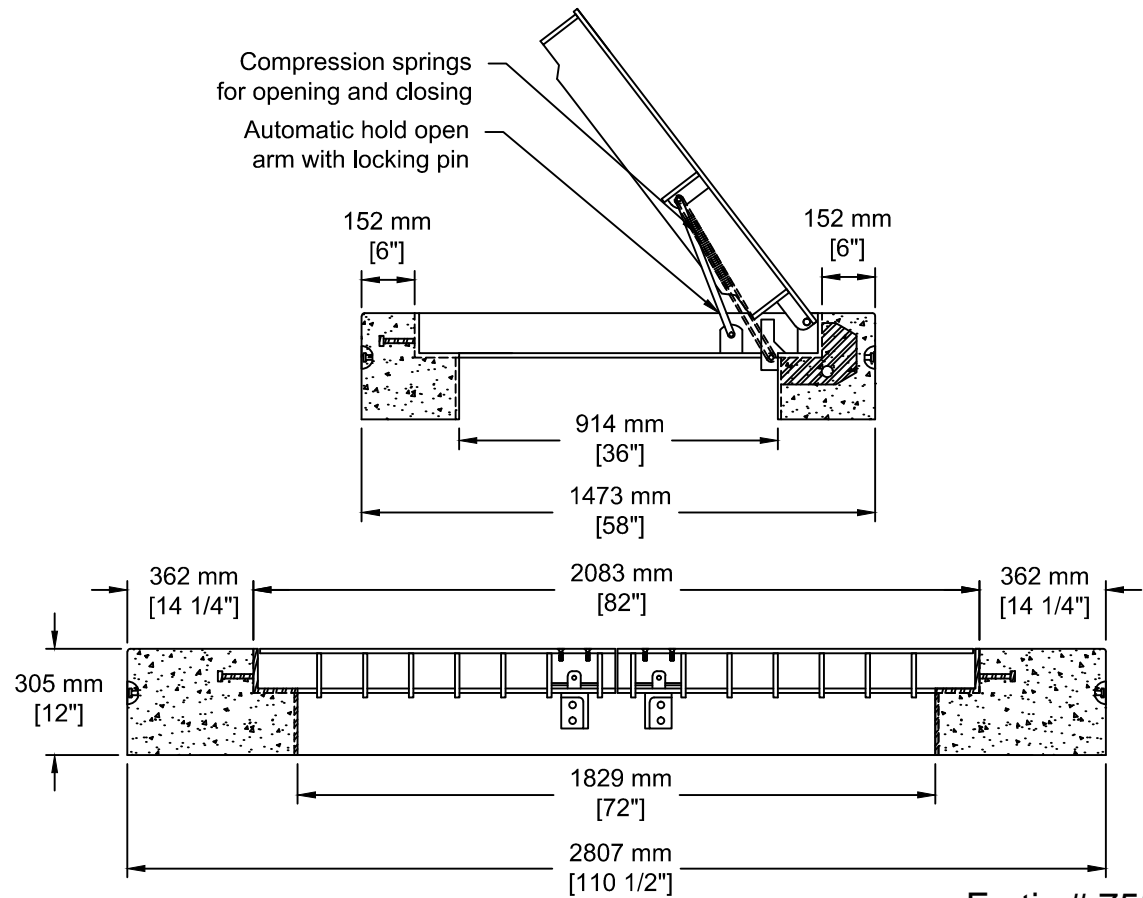

Fortis # 755-0560

**SOC**  
 SOUTH OKANAGAN  
 CONCRETE PRODUCTS LTD

TEL: 250-495-7556  
 socp@socp.ca  
 www.socp.ca

Box 419, 11602 - 115 st Osoyoos, BC V0H 1V0 FAX: 250-495-3556

1594 Fortis 3 Phase 832 Junction Vault  
 Steel Lid & Concrete Collar - H20 Dynamic

Product #  
**1127**