

INSTALLATION INFORMATION

TANK - SPREADER BAR & CABLES FOR HANDLING
 CONCRETE RISER & HATCH LID SOLD SEPARATELY
 LID C/ 4 - 3/8" R-ANCHORS FOR HANDLING
 GASKET: CONSEAL BUTYL SEALANT
 WEIGHT: LBS / KG (LID)
 WEIGHT: LBS / KG (TANK)

DESIGN SPECIFICATION
 MANUFACTURED IN ACCORDANCE WITH: CSA A23.4, B-66
 ASTM C1227

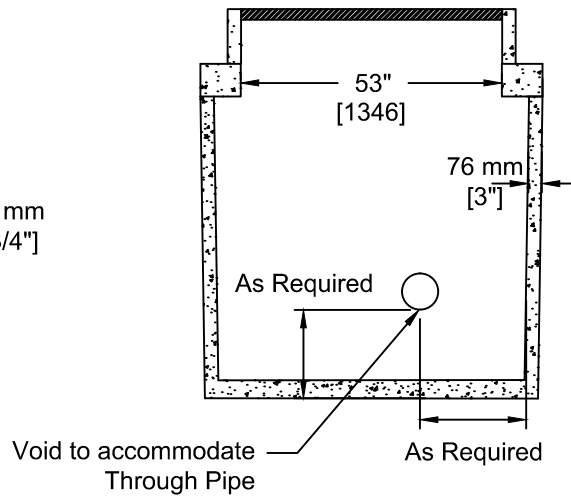
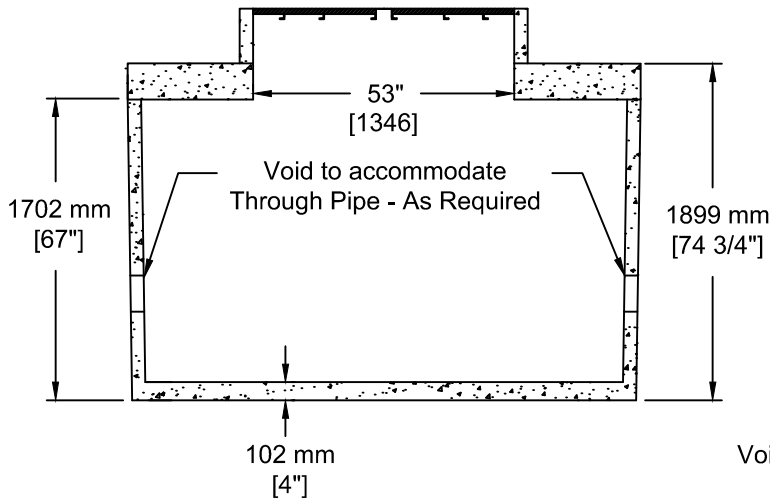

SOC
 SOUTH OKANAGAN
 CONCRETE PRODUCTS LTD

TEL: 250-495-7556
 socp@socp.ca
 www.socp.ca

Box 419, 11602 - 115 st Osoyoos, BC V0H 1V0 FAX: 250-495-3556

(1450) TS-1Ch Water Meter Chamber
 Opening

Product #
 0508