

USF TPD 889 mm x 1092 mm (35" x 43")
Hatch Style Lid: Sold Separately

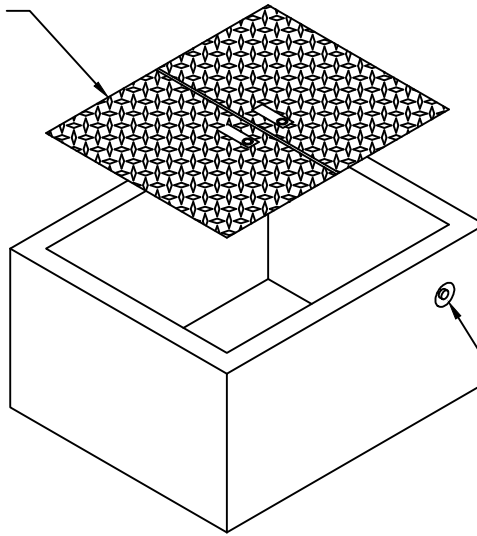

Dogbone Style
Lifting Anchors

INSTALLATION INFORMATION

2 - 2.5T DOGBONE STYLE LIFTING ANCHORS
WEIGHT: VARIES

DESIGN SPECIFICATION

MANUFACTURED IN ACCORDANCE WITH: CSA A23.4, B-66
ASTM C1227

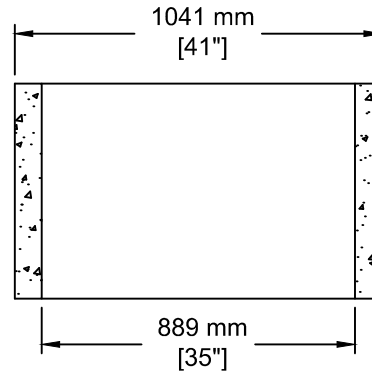
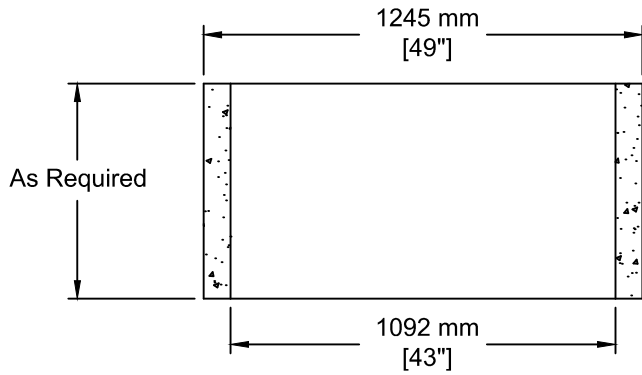

TEL: 250-495-7556
socp@socp.ca
www.socp.ca

(850) Water Meter Chamber Riser
1245 mm x 1092 mm
x Height as Required

Product #
0506-R