

INSTALLATION INFORMATION

ACCEPTS 2 - B-10 STRIP GRATES (NOT INCLUDED)

WEIGHT: 238 LBS / 108 KG

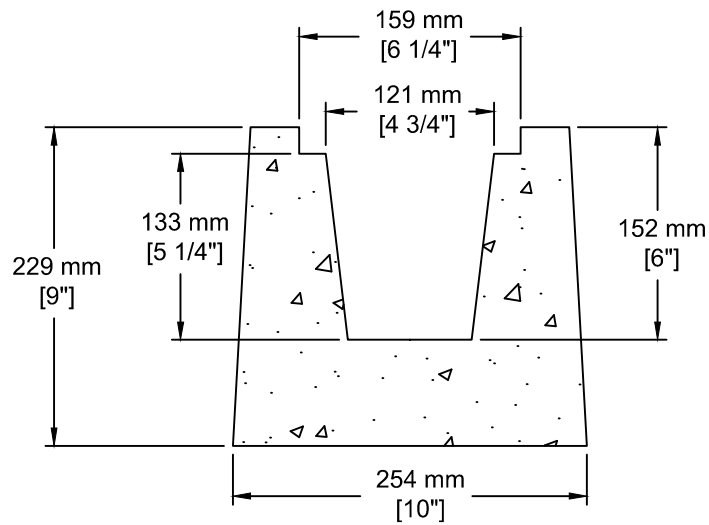

Trench Drain
(B-10 grates sold separately)

Product #

0417



TEL: 250-495-7556

socp@socp.ca

www.socp.ca

**SOUTH OKANAGAN
 CONCRETE PRODUCTS LTD**

Box 419, 11802 - 115 st Osoyoos, BC V0H 1V0

FAX: 250-495-3556