

INSTALLATION INFORMATION
DESIGN SPECIFICATION - ASTM C478
2 - 2.5T DOGBONE STYLE LIFTING ANCHORS
WEIGHT: 5361 lbs / 2433 kg

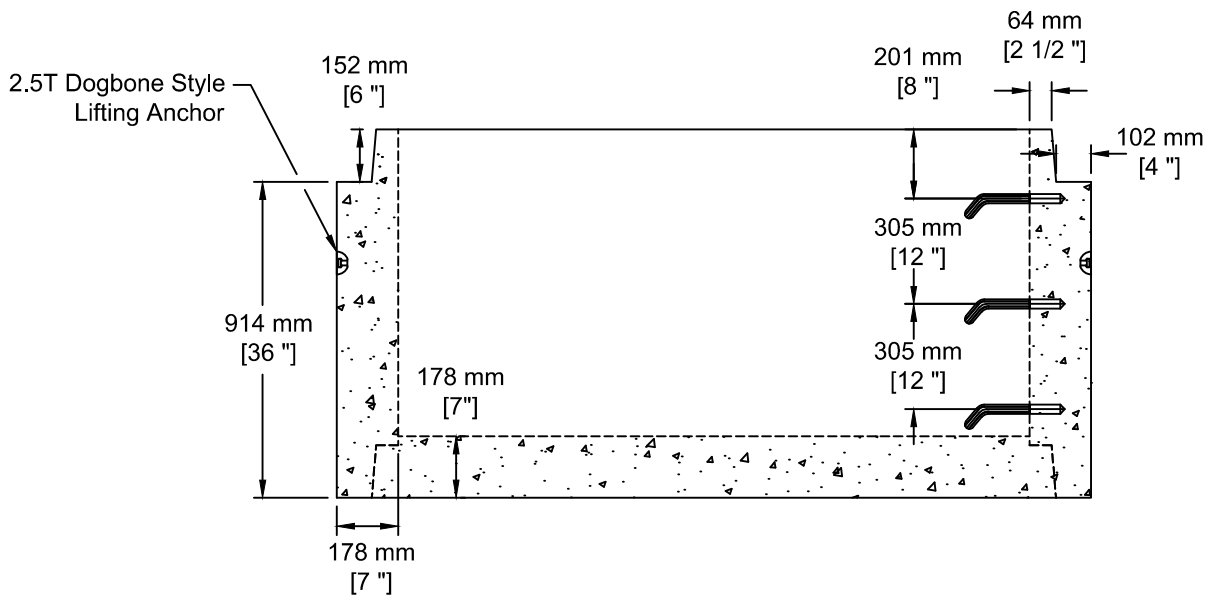

TEL: 250-495-7556
 socp@socp.ca
 www.socp.ca

1800 ID (72") Manhole
- IB c/w Inside Base

Product #

0373-IB