

**INSTALLATION INFORMATION**  
 DESIGN SPECIFICATION - ASTM C478  
 2 - 2.5T DOGBONE STYLE LIFTING ANCHORS  
 WEIGHT: 3759 LBS / 1704 KG

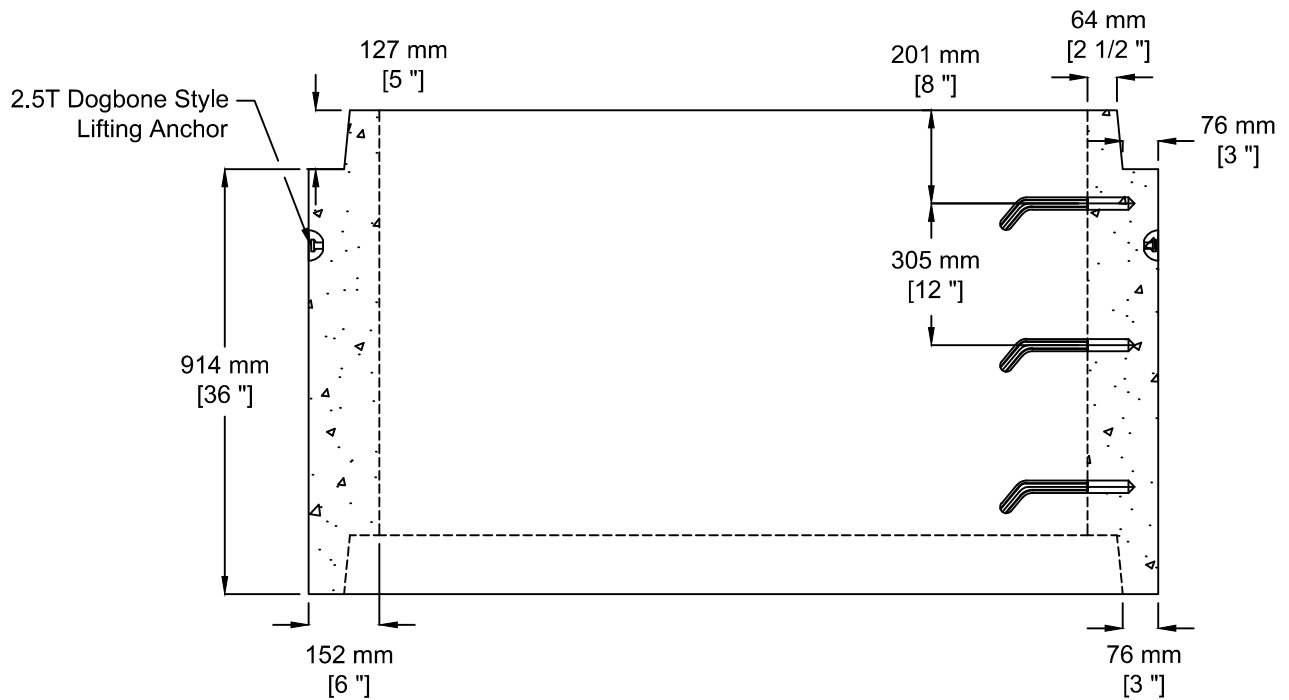

TEL: 250-495-7556  
 socp@socp.ca  
 www.socp.ca

1500 ID (60") x 0.91m  
 Manhole Riser

Product #

0363