

INSTALLATION INFORMATION
DESIGN SPECIFICATION - ASTM C478
2 - 2.5T DOGBONE STYLE LIFTING ANCHORS
WEIGHT: 3360 LBS / 1524 KG

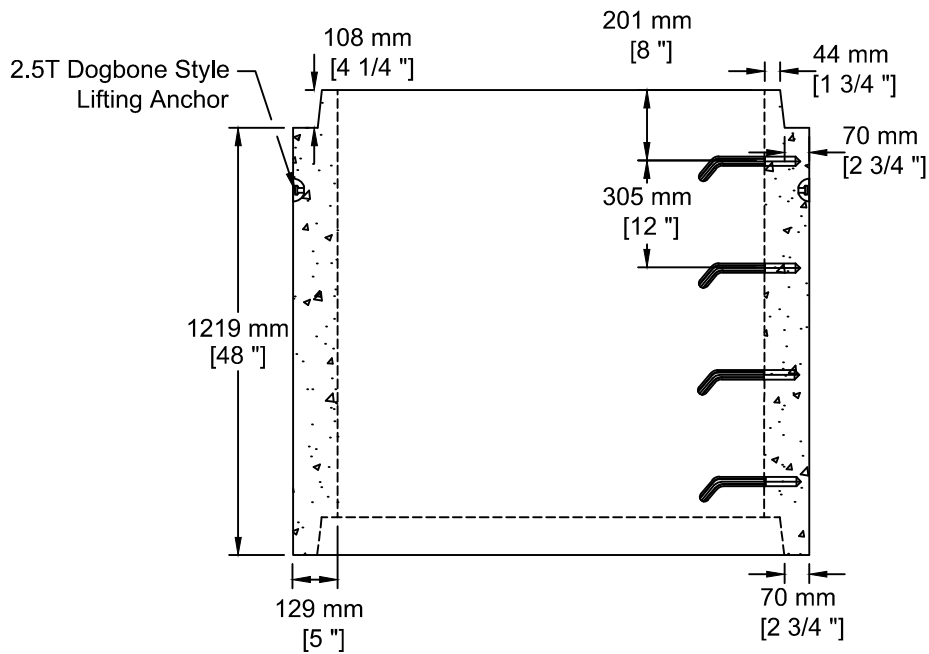

TEL: 250-495-7556
 socp@socp.ca
 www.socp.ca

Box 419, 11602 - 115 st Osoyoos, BC V0H 1V0

FAX: 250-495-3556

1200 ID (48") x 1.2vm
 Manhole Riser

Product #

0344