

INSTALLATION INFORMATION
DESIGN SPECIFICATION - ASTM C478
2 - 2.5T DOGBONE STYLE LIFTING ANCHORS
WEIGHT: 1210 LBS / 550 KG

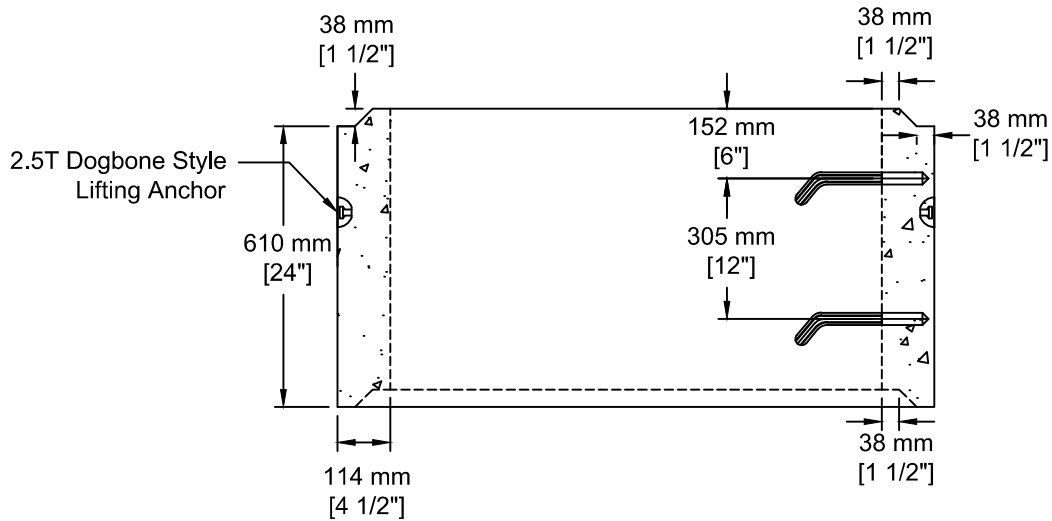

TEL: 250-495-7556
 socp@socp.ca
 www.socp.ca

1050 ID (42") x 0.61vm
 Manhole Riser

Product #
0322