

INSTALLATION INFORMATION
 4 - 25 MM (1") LIFTING HOLES
 WEIGHT: 1530 LBS / 694 KG

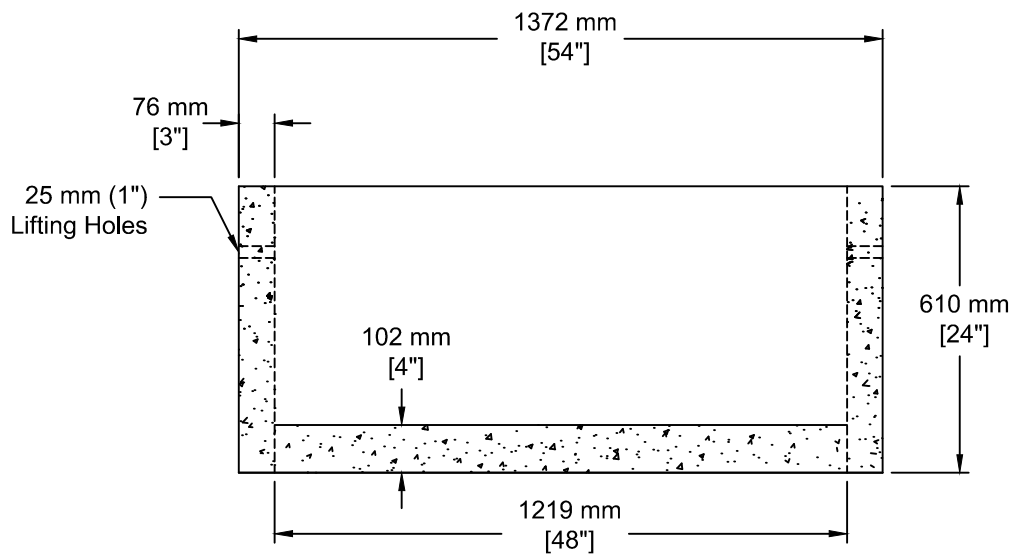

TEL: 250-495-7556
 socp@socp.ca
 www.socp.ca

Box 419, 11602 - 115 st Osoyoos, BC V0H 1V0

FAX: 250-495-3556

1200 ID (48") x 0.91vm
Well Tile - IB c/w Inside Base

Product #

0207-IB