

INSTALLATION INFORMATION
2 - 25 MM [1"] LIFTING HOLES
WEIGHT: 616 LBS / 279 KG

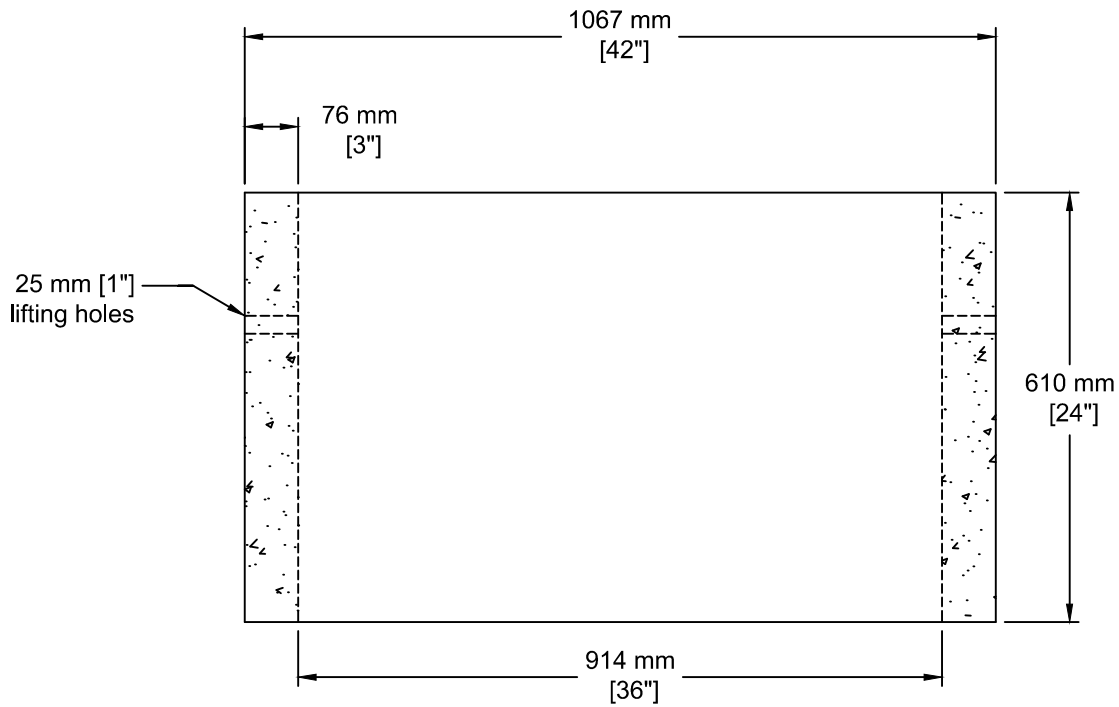

TEL: 250-495-7556
socp@socp.ca
www.socp.ca

Box 419, 11602 - 115 st Osoyoos, BC V0H 1V0

FAX: 250-495-3556

**900 ID (36") x 0.61vm
Well Tile Riser**

Product #

0203