

**INSTALLATION INFORMATION**  
 2 - 25 MM [1"] LIFTING HOLES  
 WEIGHT: 723 LBS / 327 KG

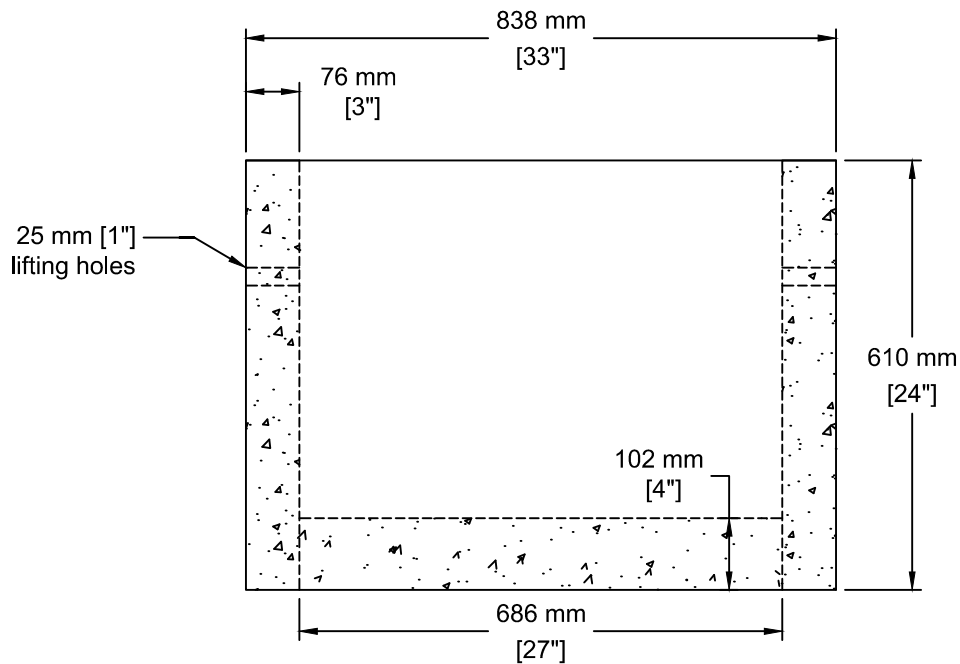

TEL: 250-495-7556  
 socp@socp.ca  
 www.socp.ca

Box 419, 11602 - 115 st Osoyoos, BC V0H 1V0

FAX: 250-495-3556

**685 ID (27") x 0.61vm**  
**Well Tile - IB c/w Inside Base**

Product #

**0201-IB**