

**INSTALLATION INFORMATION**

4 - 25 MM [1"] LIFTING HOLES

WEIGHT: 361 LBS / 164 KG

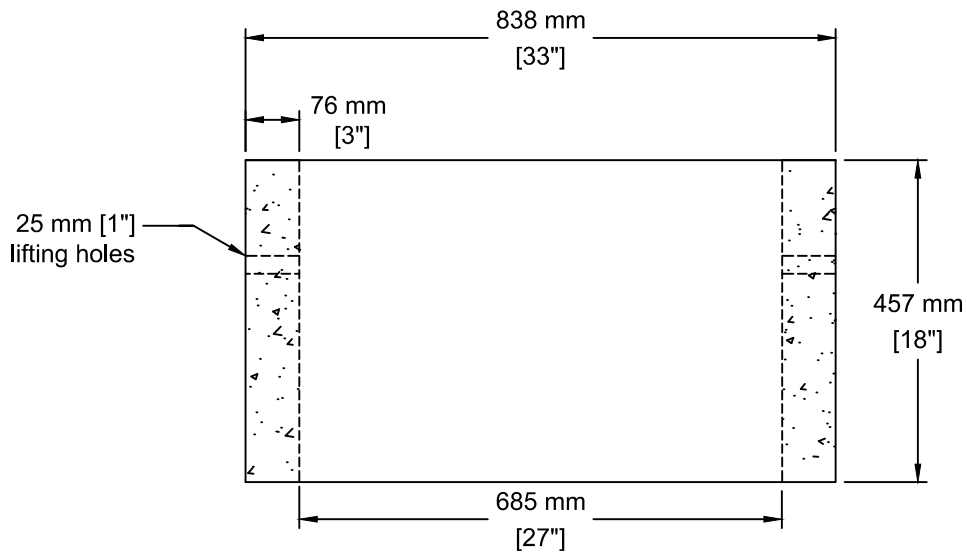

TEL: 250-495-7556  
socp@socp.ca  
www.socp.ca

Box 419, 11602 - 115 st Osoyoos, BC V0H 1V0

FAX: 250-495-3556

**685 ID (27") x 0.46vm  
Well Tile Riser**

Product #

**0201-18**