

INSTALLATION INFORMATION

TANK - SPREADER BAR & CABLES FOR HANDLING
 LID C/ 4 - 10 MM (3/8") R-ANCHORS FOR HANDLING
 GASKET: CONSEAL BUTYL SEALANT
 WEIGHT: 2900 LBS / 1315 KG (LID)
 WEIGHT: 9458 LBS / 4290 KG (TANK)

DESIGN SPECIFICATION

RESIDENTIAL LOADING
 BURIAL DEPTH - **NO GREATER THAN 1M** ASTM C1227
 CSA B-66

PLEASE NOTE : STANDARD WATER CISTERN INCLUDES INLET /
 OUTLET HOLES. ADDITIONAL FITTINGS CAN BE CAST TO ORDER

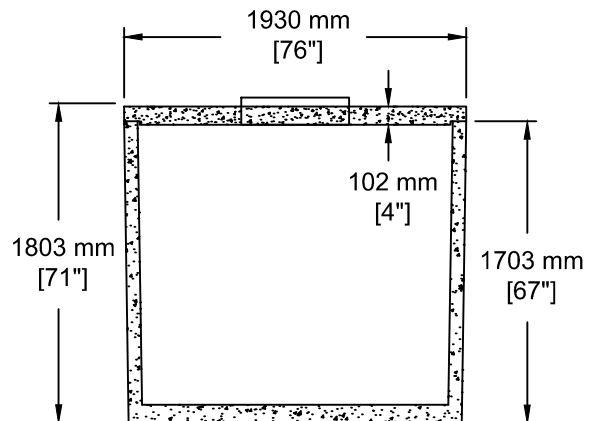
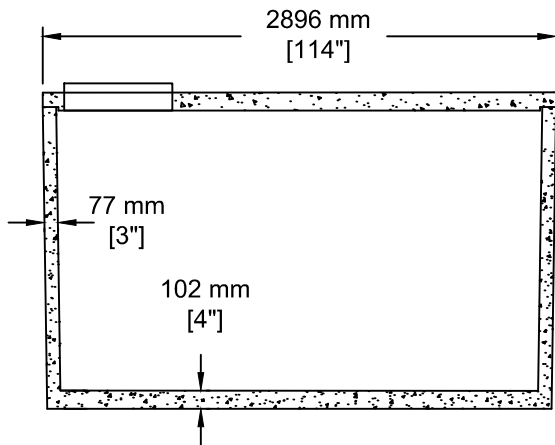

TEL: 250-495-7556
 socp@socp.ca
 www.socp.ca

Box 419, 11602 - 115 st Osoyoos, BC V0H 1V0

FAX: 250-495-3556

(1450) TS-1CH 7446 litres
 (1638 gal) Water Cistern

Product #

0183