

INSTALLATION INFORMATION

TANK - SPREADER BAR & CABLES FOR HANDLING
 LID C/ 4 - 10 MM (3/8") R-ANCHORS FOR HANDLING
 GASKET: CONSEAL BUTYL SEALANT
 WEIGHT: 2900 LBS / 1315 KG (LID)
 WEIGHT: 8200 LBS / 3720 KG (TANK)

DESIGN SPECIFICATION

RESIDENTIAL LOADING
 BURIAL DEPTH - **NO GREATER THAN 1M** ASTM C1227
 CSA B-66
NOTE : STANDARD WATER CISTERN INCLUDES INLET / OUTLET HOLES.
 ADDITIONAL FITTINGS CAN BE CAST TO ORDER

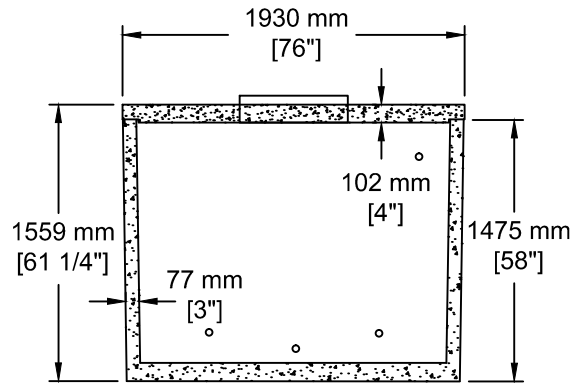
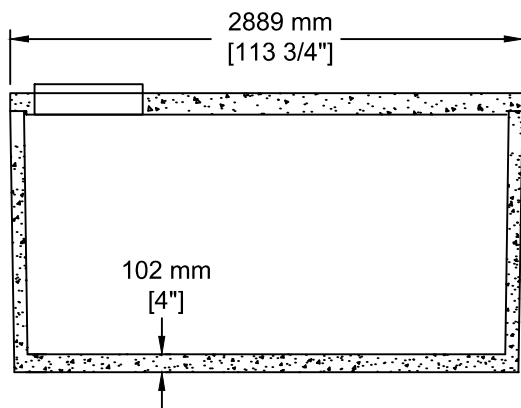

TEL: 250-495-7556
 socp@socp.ca
 www.socp.ca

**(1200) TS-1CH 6383 litres
 (1404 gal) Water Cistern**

Product #

0182