

INSTALLATION INFORMATION

TANK - SPREADER BAR & CABLES FOR HANDLING
 LID C/ 4 - 10 MM (3/8") R-ANCHORS FOR HANDLING
 GASKET: CONSEAL BUTYL SEALANT
 WEIGHT: 2200 LBS / 998 KG (LID)
 WEIGHT: 5700 LBS / 2586 KG (TANK)

DESIGN SPECIFICATION

RESIDENTIAL LOADING

BURIAL DEPTH - **NO GREATER THAN 1M** ASTM C1227

CSA B-66

PLEASE NOTE : STANDARD WATER CISTERN INCLUDES INLET /
 OUTLET HOLES. ADDITIONAL FITTINGS CAN BE CAST TO ORDER

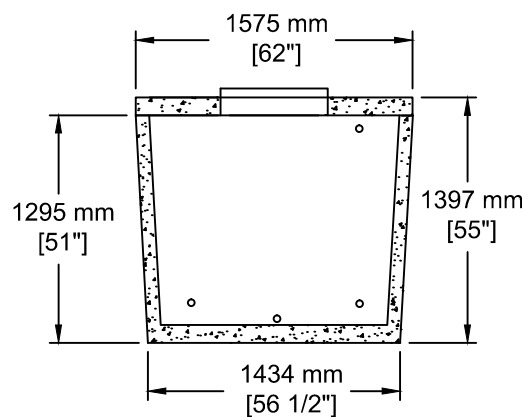
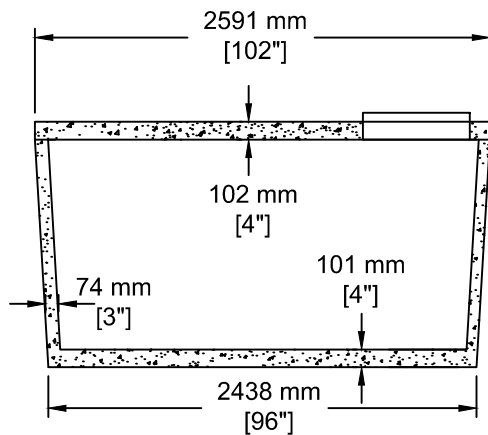

TEL: 250-495-7556
 socp@socp.ca
 www.socp.ca

(600) TS-1CH 3746 litres
 (824 gal) Water Cistern

Product #
 0180