

INSTALLATION INFORMATION

TANK - SPREADER BAR & CABLES FOR HANDLING
 LID C/ 4 - 10 MM (3/8") R-ANCHORS FOR HANDLING
 GASKET: CONSEAL BUTYL SEALANT
 WEIGHT: 2900 LBS / 1315 KG (LID)
 WEIGHT: 9458 LBS / 4290 KG (TANK)

DESIGN SPECIFICATION
 RESIDENTIAL LOADING
 BURIAL DEPTH - **NO GREATER THAN 1M** ASTM C1227
 CSA B-66

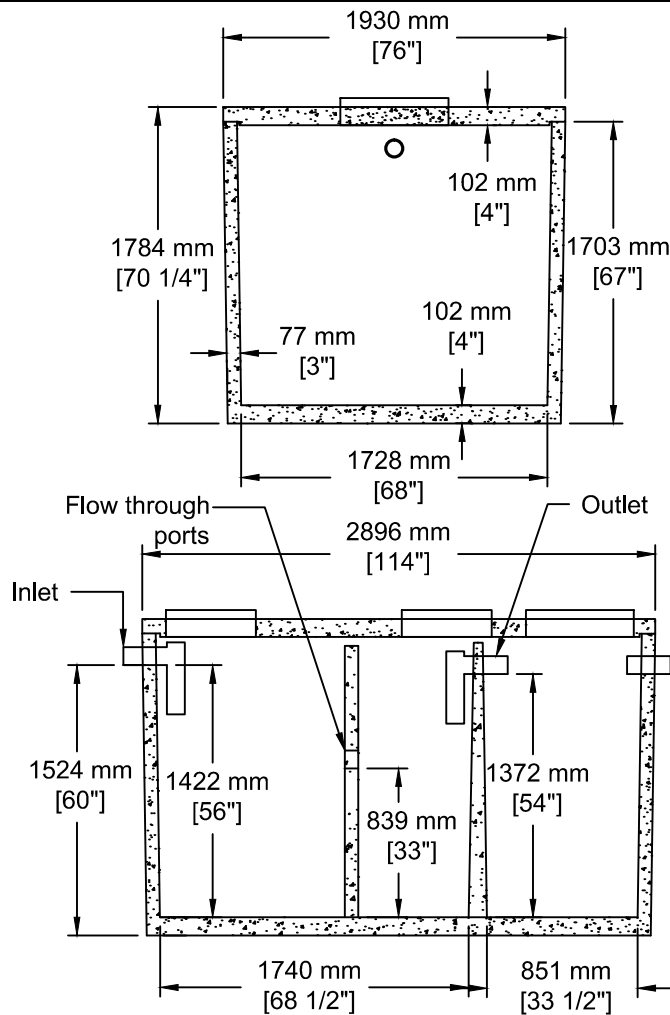

SOCPC
 SOUTH OKANAGAN
 CONCRETE PRODUCTS LTD
 Box 419, 11602 - 115 st Osoyoos, BC V0H 1V0
 TEL: 250-495-7556
 socp@socp.ca
 www.socp.ca
 FAX: 250-495-3556

(1450) TS-3Ch 4410 litres (970 gal)
 2-Comp Septic Tank / 2182 litres (480 gal)
 Pump Chamber

Product #
 0139