

INSTALLATION INFORMATION

- 4 - 5T DOGBONE STYLE LIFTING ANCHORS (LID)
- 4 - 5T DOGBONE STYLE LIFTING ANCHORS (TANK)
- GASKET: CONSEAL BUTYL SEALANT

DESIGN SPECIFICATION
RESIDENTIAL LOADING
BURIAL DEPTH - NO GREATER THAN 1M
 MANUFACTURED IN ACCORDANCE WITH:
 CSA A23.4, B-66
 ASTM C1227

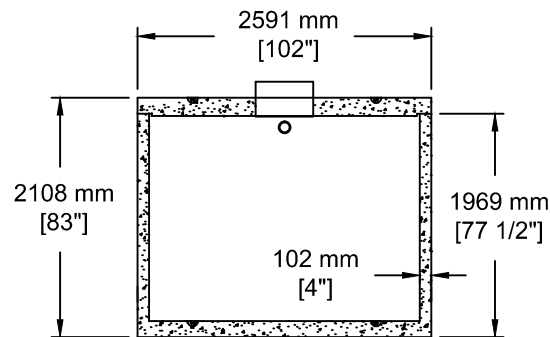
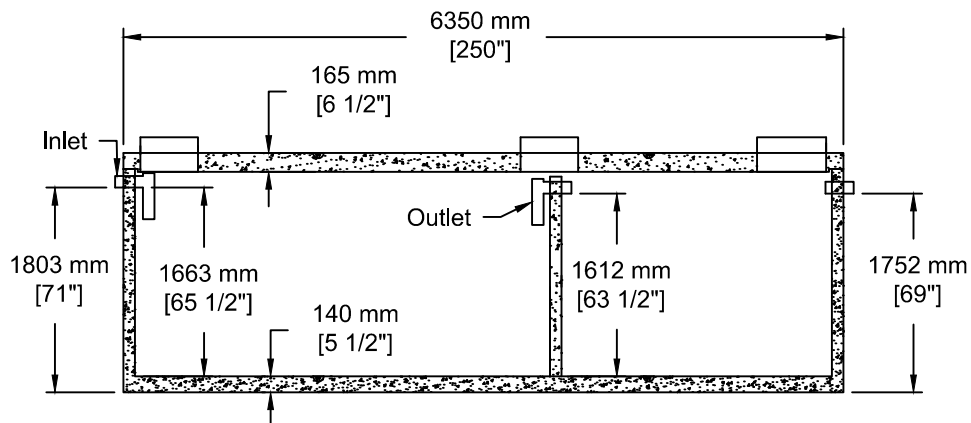

TEL: 250-495-7556
 socp@socp.ca
 www.socp.ca

Box 419, 11602 - 115 st Osoyoos, BC V0H 1V0

FAX: 250-495-3556

(5000) TS-2Ch 15229 litres (3350 gal)
 1-Comp Septic Tank / 7500 litres (1600 gal)
 Pump Chamber

Product #
 0135-50