

**INSTALLATION INFORMATION**

4 - 5T DOGBONE STYLE LIFTING ANCHORS (LID)  
 4 - 5T DOGBONE STYLE LIFTING ANCHORS (TANK)  
 GASKET: CONSEAL BUTYL SEALANT

**DESIGN SPECIFICATION**  
**RESIDENTIAL LOADING**

BURIAL DEPTH - **NO GREATER THAN 1M**  
 MANUFACTURED IN ACCORDANCE WITH: CSA A23.4, B-66  
 ASTM C1227

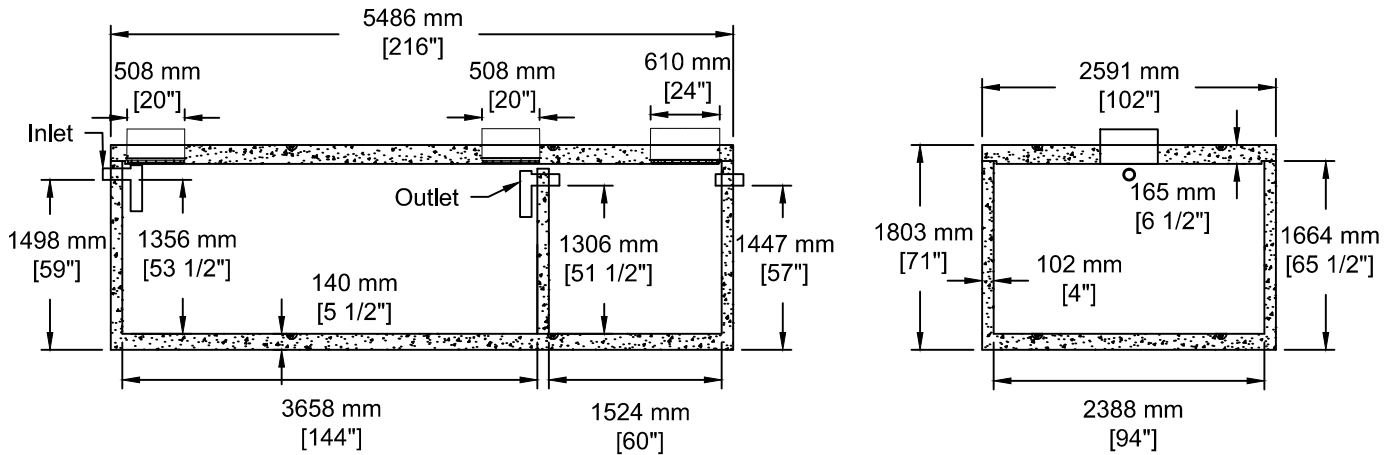

TEL: 250-495-7556  
 socp@socp.ca  
 www.socp.ca

Box 419, 11602 - 115 st Osoyoos, BC V0H 1V0 FAX: 250-495-3556

(3500) TS-2Ch 10660 litres (2345 gal)  
 1-Comp Septic Tank / 5250 litres (1155 gal)  
 Pump Chamber

Product #  
 0135-35