

**INSTALLATION INFORMATION**  
 4 - 5T DOGBONE STYLE LIFTING ANCHORS (LID)  
 4 - 5T DOGBONE STYLE LIFTING ANCHORS (TANK)  
 GASKET: CONSEAL BUTYL SEALANT

**DESIGN SPECIFICATION**  
 RESIDENTIAL LOADING  
 BURIAL DEPTH - **NO GREATER THAN 1M**  
 MANUFACTURED IN ACCORDANCE WITH: CSA A23.4, B-66  
 ASTM C1227

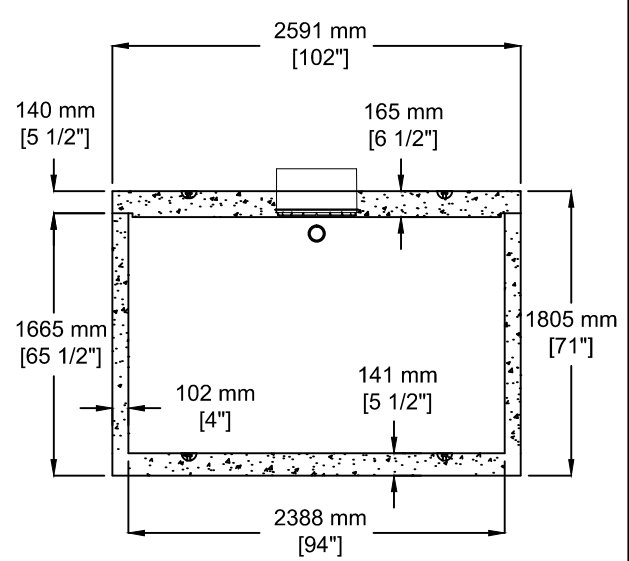
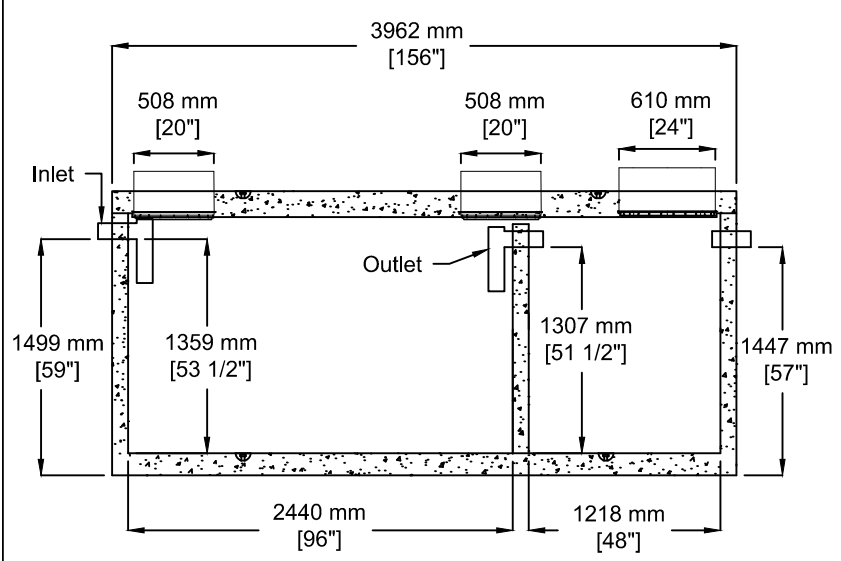

**SOC**  
 SOUTH OKANAGAN  
 CONCRETE PRODUCTS LTD

TEL: 250-495-7556  
 socp@socp.ca  
 www.socp.ca

Box 419, 11602 - 115 st Osoyoos, BC V0H 1V0 FAX: 250-495-3556

(2500) TS-2Ch 7615 litres (1675 gal)  
 1-Comp Septic Tank / 3750 litres (825 gal)  
 Pump Chamber

Product #  
 0135-25