

INSTALLATION INFORMATION

- 4 - 5T DOGBONE STYLE LIFTING ANCHORS (LID)
- 4 - 5T DOGBONE STYLE LIFTING ANCHORS (TANK)
- GASKET: CONSEAL BUTYL SEALANT

DESIGN SPECIFICATION
RESIDENTIAL LOADING

BURIAL DEPTH - **NO GREATER THAN 1M**
MANUFACTURED IN ACCORDANCE WITH: CSA A23.4, B-66
ASTM C1227

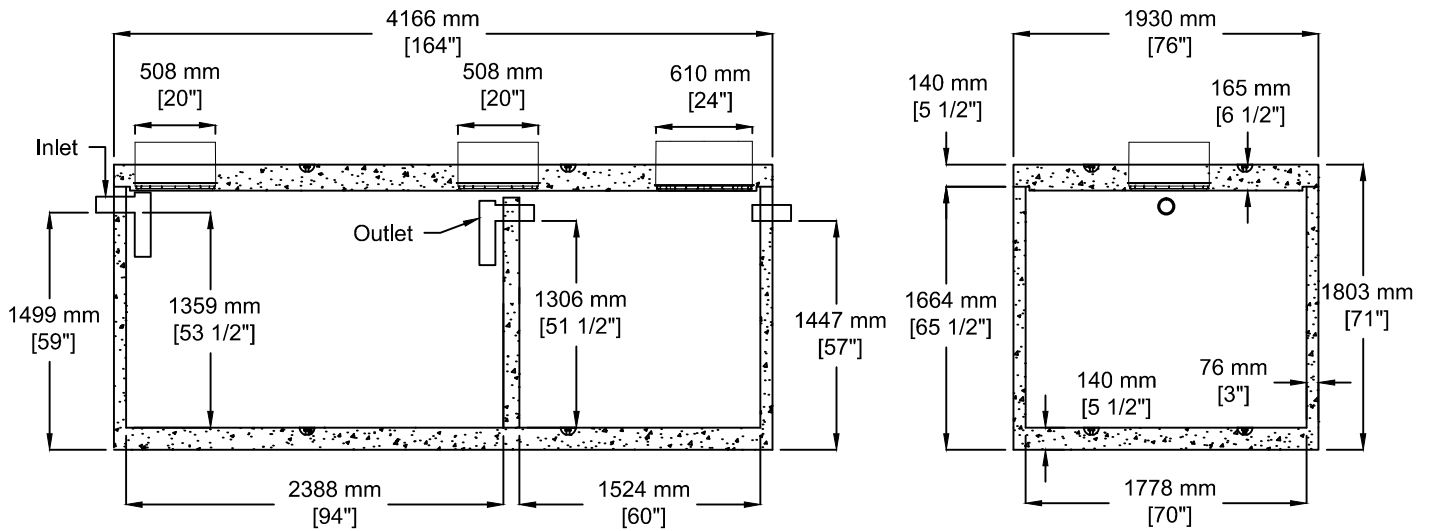

SOCPC
SOUTH OKANAGAN
CONCRETE PRODUCTS LTD

TEL: 250-495-7556
socpc@socpc.ca
www.socpc.ca

Box 419, 11602 - 115 st Osoyoos, BC V0H 1V0 FAX: 250-495-3556

(2000) TS-2Ch 6092 litres (1340 gal)
1-Comp Septic Tank / 3000 litres (660 gal)
Pump Chamber

Product #
0135-20