

**INSTALLATION INFORMATION**

TANK - SPREADER BAR & CABLES FOR HANDLING  
 LID C/ 4 - 10 MM (3/8") R-ANCHORS FOR HANDLING  
 GASKET: CONSEAL BUTYL SEALANT  
 WEIGHT: 2900 LBS / 1315 KG (LID)  
 WEIGHT: 9200 LBS / 4173 KG (TANK)

**DESIGN SPECIFICATION**  
 RESIDENTIAL LOADING  
 BURIAL DEPTH - **NO GREATER THAN 1M** ASTM C1227  
 CSA B-66

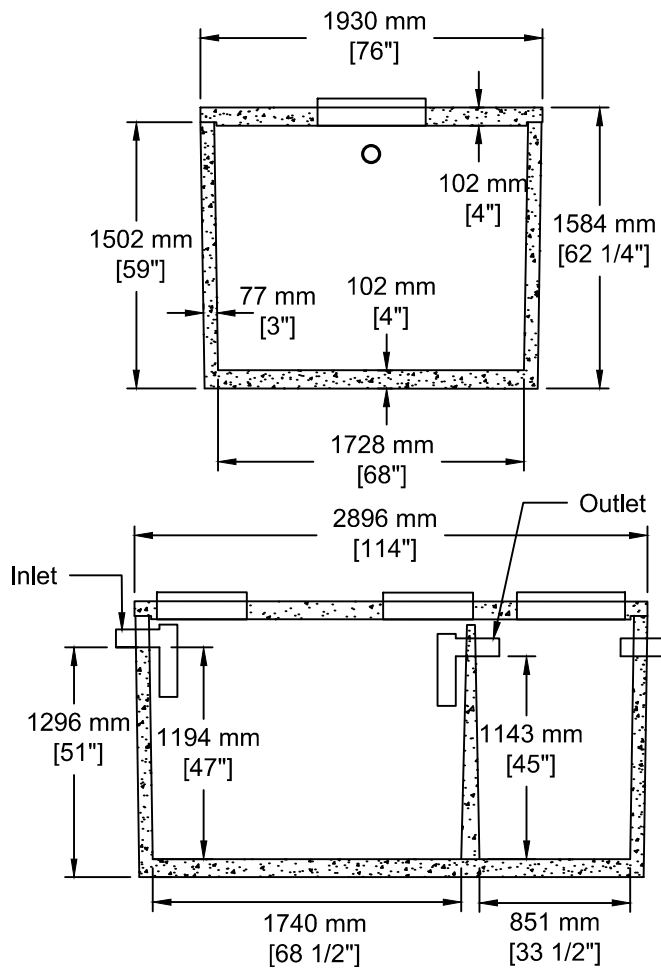

**SOC**  
 SOUTH OKANAGAN  
 CONCRETE PRODUCTS LTD

TEL: 250-495-7556  
 socp@socp.ca  
 www.socp.ca

Box 419, 11602 - 115 st Osoyoos, BC V0H 1V0 FAX: 250-495-3556

(1200) TS-2Ch 3636 litres (800 gal)  
 1-Comp Septic Tank / 1818 litres (400 gal)  
 Pump Chamber

Product #  
 0132