

INSTALLATION INFORMATION

TANK - SPREADER BAR & CABLES FOR HANDLING
 LID C/ 4 - 3/8" R-ANCHORS FOR HANDLING
 GASKET: CONSEAL BUTYL SEALANT
 WEIGHT: 2900 LBS / 1315 KG (LID)
 WEIGHT: 9458 LBS / 4290 KG (TANK)

**DESIGN SPECIFICATION
 RESIDENTIAL LOADING**

BURIAL DEPTH - **NO GREATER THAN 1M**
 MANUFACTURED IN ACCORDANCE WITH:
 CSA A23.4, B-66
 ASTM C1227

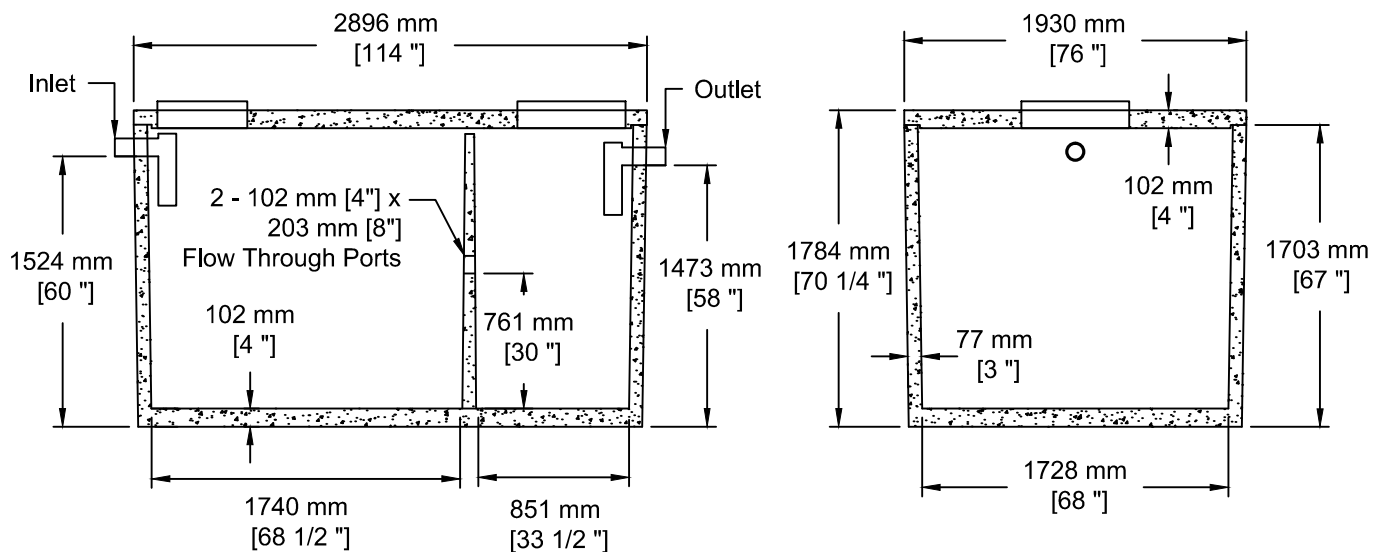

SOC
 SOUTH OKANAGAN
 CONCRETE PRODUCTS LTD

TEL: 250-495-7556
 socp@socp.ca
 www.socp.ca

Box 419, 11602 - 115 st Osoyoos, BC V0H 1V0 FAX: 250-495-3556

TS-2Ch 6592 litres (1450 gal)
 Septic Tank

Product #
 0126