

**INSTALLATION INFORMATION**

SPREADER BAR & CABLES FOR HANDLING  
 GASKET: 1" CONSEAL BUTYL SEALANT  
 WEIGHT: 3880 LBS / 1760 KG (TOP)  
 WEIGHT: 3540 LBS / 1606 KG (BOTTOM)

**DESIGN SPECIFICATION  
 RESIDENTIAL LOADING**

BURIAL DEPTH - **NO GREATER THAN 1M**  
 MANUFACTURED IN ACCORDANCE WITH:  
 CSA A23.4, B-66  
 ASTM C1227

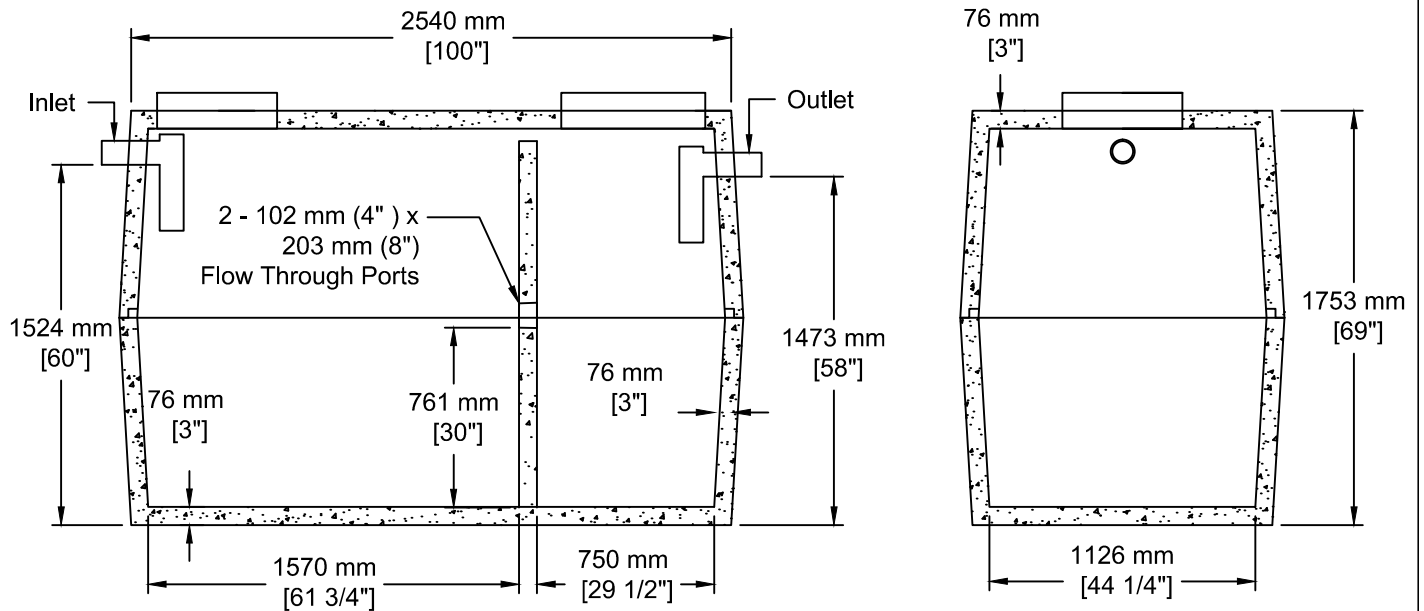

**SOC**  
 SOUTH OKANAGAN  
 CONCRETE PRODUCTS LTD

TEL: 250-495-7556  
 socp@socp.ca  
 www.socp.ca

Box 419, 11602 - 115 st Osoyoos, BC V0H 1V0 FAX: 250-495-3556

MS-2Ch 3636 litres (800 gal)  
 Septic Tank

Product #  
 0116