

INSTALLATION INFORMATION

SPREADER BAR & CABLES FOR HANDLING
 GASKET: 1" CONSEAL BUTYL SEALANT
 WEIGHT: 5700 LBS / 2585 KG (TOP)
 WEIGHT: 4400 LBS / 2014 KG (BOTTOM)

DESIGN SPECIFICATION
 RESIDENTIAL LOADING

BURIAL DEPTH - **NO GREATER THAN 1M**
 MANUFACTURED IN ACCORDANCE WITH: CSA A23.4, B-66
 ASTM C1227

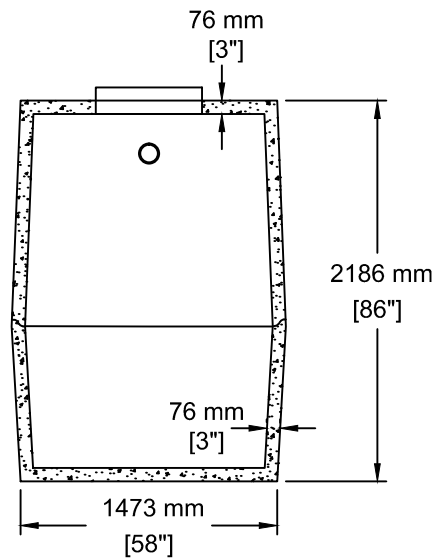
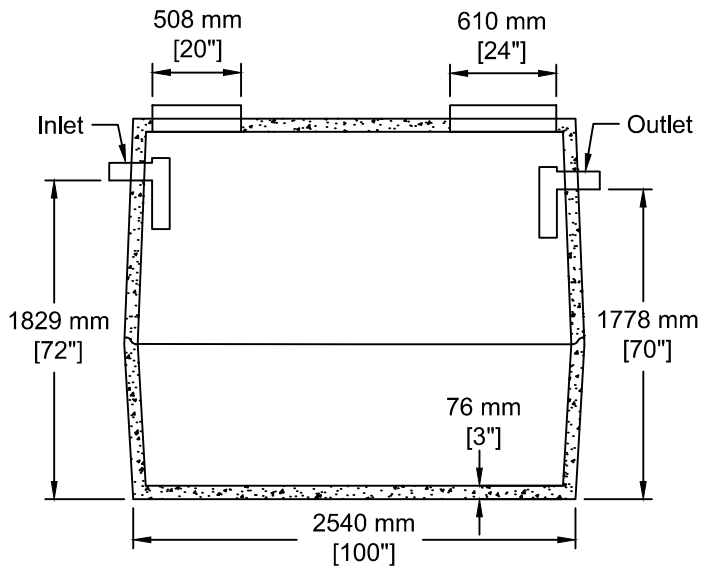

TEL: 250-495-7556
 socp@socp.ca
 www.socp.ca

MS-1Ch 5455 litres (1200 gal)
 Septic Tank

Product #

0105