

INSTALLATION INFORMATION

SPREADER BAR & CABLES FOR HANDLING
 GASKET: 1" CONSEAL BUTYL SEALANT
 WEIGHT: 3880 LBS / 1760 KG (TOP)
 WEIGHT: 3900 LBS / 1769 KG (BOTTOM)

DESIGN SPECIFICATION
 RESIDENTIAL LOADING

BURIAL DEPTH - **NO GREATER THAN 1M**
 MANUFACTURED IN ACCORDANCE WITH: CSA A23.4, B-66
 ASTM C1227

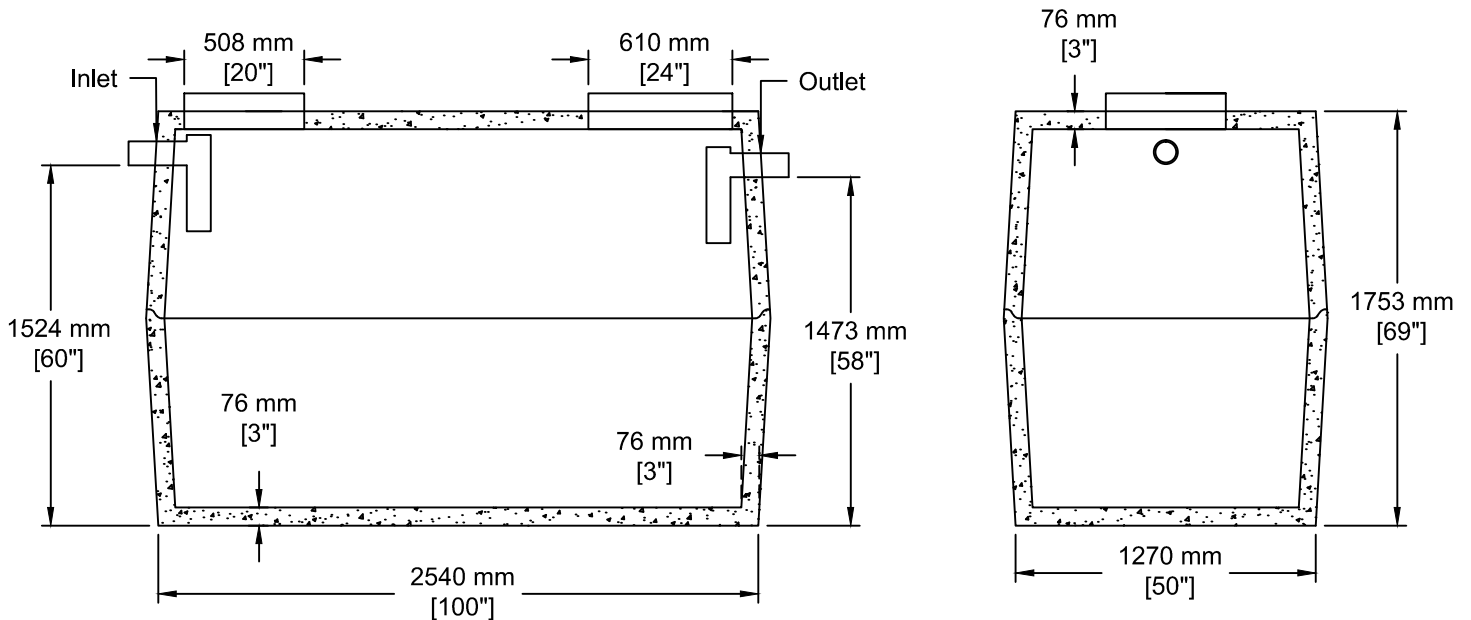

TEL: 250-495-7556
 socp@socp.ca
 www.socp.ca

Box 419, 11602 - 115 st Osoyoos, BC V0H 1V0

FAX: 250-495-3556

MS-1Ch 3636 litres (800 gal)
 Septic Tank

Product #

0103